

RoHS

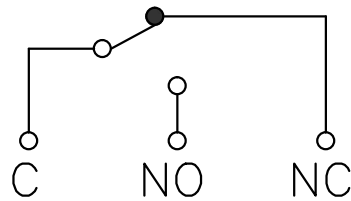

Circuit Diagram

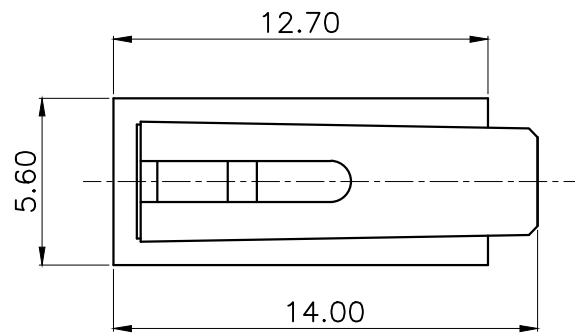
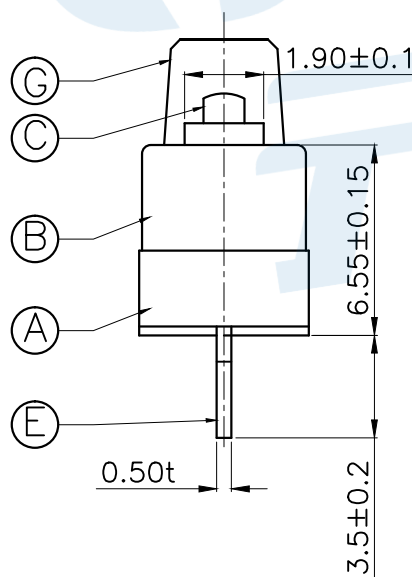
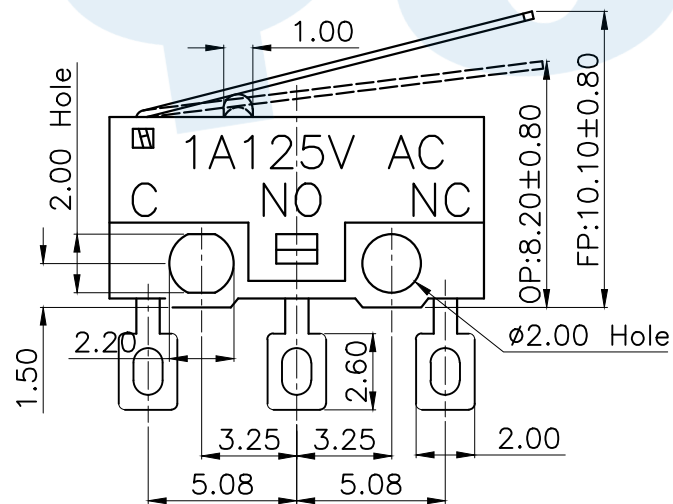

Operating force
30±15gf

Contact material	
CODE	MATERIAL
T	Copper dot
Y	Silver dot

NO.	Name	Number	Qty	Materil	Remarks
Ⓒ	Pressure handle	1	1	SUS	
Ⓕ	Contact	1	1	Silver/copper dot	
Ⓔ	Terminal	3	3	Brass	Silver
Ⓖ	Contact reed	1	1	Brass	
Ⓒ	Handle	1	1	POM	White
Ⓑ	Cover	1	1	PBT	Black
Ⓐ	Base	1	1	PBT	Black

YUANDI® Yuandi Electronics Co, Ltd

design	date	name	MICRO SWITCH
Review	date	model	TC-5610L-□
Approved	date		

Drawing number: Proportion 1:1 unit mm gage number A4

modify Review Approved Tolerance not specified

angle	±2'
10~30	±0.30
5~10	±0.20
~ 5	±0.10